

RENU UF ULTRAFILTRATION SYSTEM

Provide multiple equipment needs with high volume of quality water



Renu UF-FC10BB
SA31025



Renu UF-FC20BB
SA31026

Applications

- ◆ High flow rate food service applications including "Point-of-Entry" treatment of supply water used in restaurants, convenience stores, bubble tea stores and etc.

Features • Benefits

- ◆ UF Membrane Pretreatment Filter uses ultrafiltration (UF) hollow fiber membranes to remove vast majority of dirt and particles down to 0.02-micron by mechanical means.
- ◆ Especially suitable for the areas suffering from massive particles, high frequency of membrane blockage. It can reduce the frequency of cartridge replacement and lengthen the service life.
- ◆ Customisable auto back-flush.
- ◆ Ultrafiltration (UF) hollow filter membrane can effectively filter particles over 0.02µm, with automatic back-flush function for longer service life, and higher capacity.
- ◆ The unique Fibredyne activated carbon filter can effectively reduce the odour taste of chlorine and other effects, improve the odour and taste of the beverage but with no sacrifice to the flow rate and capacity.
- ◆ Sturdy and compact structure.

Installation Tips

- ◆ Choose a mounting location suitable to support the weight of the system while operating.
Renu UF-FCB10BB: 46kg
Renu UF-FC20BB: 53kg
- ◆ Install the Renu UF near the socket.
- ◆ The uninterrupted power supply socket is highly recommended.
- ◆ Leave 20cm of clear space around the system to connect the inlet/outlet piping.
- ◆ Allow space below the system for maintenance access to remove the filter bowl and to replace cartridge.
(Recommended to install the system minimum 50cm up off the floor)
- ◆ Install in a location with an accessible floor drain to connect flush line (drain must be able to accommodate a discharge flow rate of up to 15ℓpm @ 50psi).

Operation Tips

- ◆ 1st stage UF membrane hollow fiber cartridge life is approximately three (3) years.
- ◆ Replace 2nd stage Fibredyne cartridge on a regular 6-month preventative maintenance program.
- ◆ Replace the filter cartridge when it reaches capacity or insufficient water flow.
- ◆ Flush to activate the cartridges each time after installation or replacement

RENU UF ULTRAFILTRATION SYSTEM

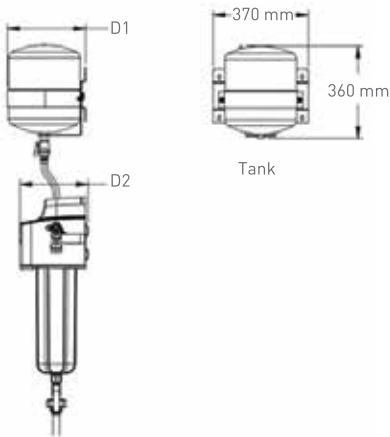
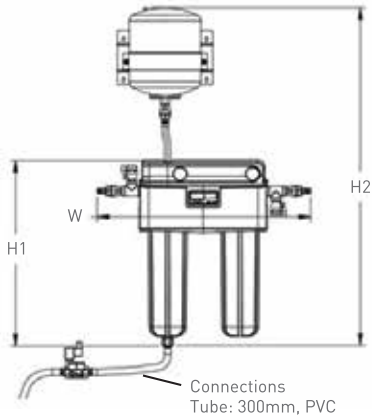

Specifications

	Renu UF-FC10BB	Renu UF-FC20BB
Part Number	SA31025	SA31026
Capacity *Tested in lab	30,000 gallons	75,000 gallons
Flow Rate *Tested in lab	3gpm / 11.35Lpm	5gpm / 18.92Lpm
Peak Flow Rate *Tested in lab	4gpm / 15.14Lpm	8gpm / 30.28Lpm
Dimension (HxWxD)	1180x825x305 mm	1440x825x305 mm
Micron Rate	0.02µm	
Pressure Requirements	20-50psi(1.4-3.5bar)	
Temperature	35-100°F(2-38°C)	
Electrical Connection	100 - 240V, 50/60Hz	
Connections	3/4" NPT-F	
Shipping Weight	24kg	28kg

Installation Size

Part Number	H1 (mm)	H2 (mm)	W (mm)	D1 (mm)	D2 (mm)
SA31025	460	1180	825	305	265
SA31026	720	1440	825	305	265

Warranty

You have just purchased one of the finest water treatment units made. As an expression of confidence in this product, Pentair Filtration Solutions, LLC ("PFS") offers the following product warranty. This product is warranted against material defects in materials and workmanship to the original end-user when installed in accordance with the PFS specifications. The warranty period commences on the date of purchase and is administered as follows:

For a period of ONE YEAR Replaceable elements (i.e., filter & water treatment cartridges)*

For a period of ONE YEAR The entire system (excluding replaceable elements)

The unit must be used in operating conditions that conform to PFS's recommended guidelines.

This warranty will not apply if the unit has been modified, repaired or altered by someone not authorized by PFS.

If a part described above is found to have a material defect in materials or workmanship within the specified warranty period, you should notify Pentair® Everpure technical service. Any part found materially defective within the terms of this warranty will be repaired or replaced [at PFS's discretion] by your local dealer or Pentair Everpure technical service. You pay only freight from our factory and local dealer charges. Any item repaired or replaced pursuant to this warranty will be covered under the original warranty terms of the system.

Notice: The contaminants or other substances that are removed by the potable water system are substances that are not needed in the water. Do not use microbial contaminated water or water without adequate disinfection before and after the system. Sterilized water, such as filtered cyst spores, can be treated with systematic removal of cyst spores.

* Warranty applies to material defects in materials & workmanship only.



Pentair Offices in South East Asia

Singapore
390 Havelock Road
#04-01 King's Centre
Singapore 169662
Tel: +6567685900

Thailand
16th Floor, The Ninth Towers
Grand RAMA 9, Tower B
33/4 Rama 9 Road, Huaykwang
Bangkok 10310, Thailand
Tel: +6621681092

Philippines
5th Floor MAIA Suites
1747 Nicanor Garcia Street corner
D.Oliman Street Makati City, Philippines
Tel: +632824 3825

All Pentair trademarks and logos are owned by Pentair. All other brands or product names are trademarks or registered marks of their respective owners. Because we are continuously improving our products and services. Pentair reserves the right to change specifications without prior notice. Pentair is an equal opportunity employer.
©2022 Pentair. All Rights Reserved.