

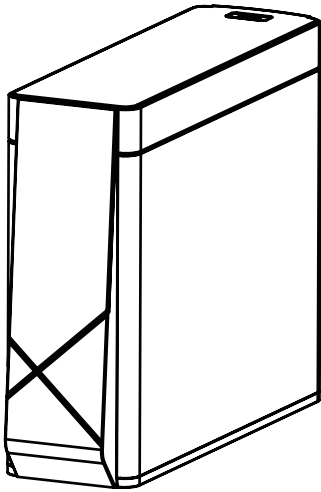

PENTAIR

**ENERGON REVERSE OSMOSIS
WATER PURIFICATION SYSTEM
USER'S MANUAL**



MODEL: V3000-SEA, V15-SEA

CONTENTS

1. PRECAUTIONS AND GENERAL NOTES	3
2. PARTS INCLUDED	4
3. PRODUCT INFORMATION	5
3.1 Product Structure	5
3.2 Product Features	5
3.3 Specifications	6
3.4 Schematic Diagrams	6
3.5 Introduction to Main Parts	7
4. INSTALLATION AND COMMISSIONING	8
4.1 Tools and Materials	8
4.2 Installation Precautions and Requirements	9
4.3 Quick Connect Instruction	9
4.4 Installation Steps	10
5. OPERATING INSTRUCTIONS	12
5.1. Initial Start-up Instructions	12
5.2 Normal Operation	13
5.3 Water Purification System Monitoring	14
6. MAINTENANCE AND CARE	14
6.1 Filter Cartridge Replacement Cycle	14
6.2 Steps for Replacement of Filter Cartridge	15
6.3 Filter Cartridge Lifespan Reset	15
6.4. Water Purification System Exterior Cleaning	15
7. TROUBLESHOOTING	16
8. TERMS AND CONDITIONS OF WARRANTY	17
9. MAINTENANCE RECORDS	17

1. PRECAUTIONS AND GENERAL NOTES

CAUTION

Please read this instruction manual carefully before installing and using this product. If you encounter any problems that are not addressed in this manual, please contact your local Pentair's distributor.

⚠WARNING:

- To prevent damage to the system or property, electric shock or personal injuries, carefully read and follow this manual.
- Do not use with water that is microbiologically unsafe or of unknown quality without adequate disinfection before or after the system.
- This reverse osmosis system will not protect against disease causing bacteria or remove naturally-occurring harmless bacteria.
- The water purification system must be installed to the cold water supply line.
- Avoid installing this product to pipelines with water hammer effects for extended period of time. Otherwise, an additional pressure control valve must be installed.
- Do not place the product under direct sunlight, or in places with high temperature or outdoors.
- Keep the product away from heat sources.
- This product contains electronic components. Do not immerse or expose to water.
- RO System must be protected against freezing, which can cause cracking of the RO components and water leakage. Any damage caused by freezing is not covered by warranty.
- Make certain that installation complies with all state and local laws and regulations.
- The installation, commissioning and maintenance of this product must be carried out by qualified technicians designated by an authorized Pentair's distributor.
- Please contact your local Pentair authorized distributor for product installation, commissioning, maintenance and after-sales services.
- Before installation, please ensure that the equipment is turned off and that the cold water supply valve is closed.
- During Installation, consider the convenience of use and the room for movement during maintenance.
- Do not touch the power plug with wet hands, and disconnect the power supply during installation.
- Before using the water purification system, make sure that the cold water valve is open, and that there is water pressure in the pipe network (water supply available).
- It is normal for small amount of carbon particles to appear after installation or filter replacement. Flush the system until carbon particles are cleared.
- Do not operate the system when inlet water temperature range extends beyond 5-38°C.
- Your water must be within required limits for satisfactory operation. If not, your membrane life may be shortened and your warranty will be void (see Section 3.3. Specifications; on page 6).
- Children and persons with disability should use this product under the supervision of a guardian.
- The system must be maintained according to manufacturer's recommendations, including replacement of filter cartridges. The contaminants or other substances removed or reduced by the selected cartridge are not necessarily in your water. Ask your local water municipality for a copy of their water analysis, or have your water tested by a reputable water testing lab.

- Keep the system powered on continuously during its normal use to ensure optimum lifespan of the filter cartridges. If the product will not be used for more than 24 hours, turn off the water and power supply.
- The filter cartridges used with this system have a limited service life. Changes in taste, odour, and/or flow of the filtered water being dispensed indicate the cartridge should be replaced.
- Please replace the filter cartridge regularly with a genuine Pentair filter cartridge, according to the filter cartridge replacement reminder.
- Maintenance and replacement has to be performed using parts or accessories approved by Pentair
- Use of unauthorized parts or accessories may result in reduced product performance or property damage. These are not covered by Pentair's limited warranty.
- Do not disassemble or modify the water purification system.
- After prolonged periods of non-use such as during a vacation, it is recommended that the system be flushed thoroughly. Let water run for 5-6 minutes before using.
- Keep concentrated water discharge pipe and reject drain water pipe free from restrictions. Failure to do so will result in reduced lifespan of filter cartridge or the system will not dispense water.
- If an error or leak occurs, unplug the power plug and turn off the tap water supply inlet valve immediately. Do not operate a malfunctioning product. Contact your local Pentair authorized distributor.
- Residential water purification systems are only suitable for personal and home use, and are not recommended for commercial use.
- The display value of TDS is calibrated with standard NaCl solution and may differ from other TDS measuring instruments.
- If you have any questions after installation, please contact your local Pentair authorized distributor.

2. PARTS INCLUDED

Carefully unpack unit and make sure all components are present. See checklist below for the components included with your system.

Packing List

Reverse Osmosis Water Purification System	1 unit	1/4" PE tube	3 m
Operation manual	1 booklet	3/8" PE tube	3 m
Water inlet three-way ball valve	1 set	Dual Faucet (Model: V3000-SEA)/ Single Faucet (Model: V15-SEA)	1 set
Teflon tape	1 roll	Power supply	1 unit
Pipe extractor	1 unit	1/4" blue clip	11 pieces
1/4" straight quick connector	2 pieces	3/8" blue clip	7 pieces
1/4" O ring	3 pieces	3/8" clip	3 pieces
1/4" clip	3 pieces	Filter Cartridge 1	1 piece
3/8" O ring	3 pieces	Filter Cartridge 2	1 piece
1/4" elbow	2 pieces	Filter Cartridge 3	1 piece
3/8" elbow	2 pieces	Water leak detector	1 set

3. PRODUCT INFORMATION

3.1. Product Structure

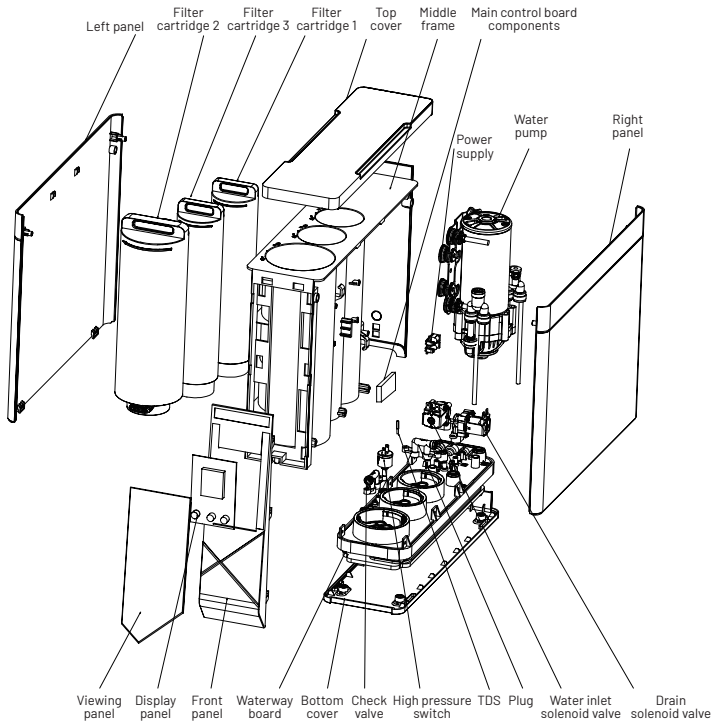

3.2. Product Features

- Provides two grades of water quality: (1) Filtered (Clean) Water and (2) RO (Pure) Water for different water usage (Model V3000-SEA only).
- RO (Pure) water can be used for drinking and cooking.
- Filtered (Clean) water can be used for food preparation and washing (Model V3000-SEA only).
- Integrated quick change filter cartridge for easy filter replacement.
- Slim machine design allows flexible installation.



Filter Cartridges Functions

Stage 1: PP removes sediments, sand and rust; Carbon removes chlorine, colour, taste and odour.

Stage 2: Removes TDS, some organics such as chloroform and carbon tetrachloride, as well as some heavy metals like arsenic, lead and cadmium.

Stage 3: Improves taste.

3.3. Specifications

Model	V3000-SEA	V15-SEA
RO Membrane Performance	400GPD	
System Flowrate	Clean (Filtered) Water: 1.5 L/min Pure (RO) Water: 1.0 L/min	Pure (RO) Water: 1.0 L/min
Outlet(s)	Dual Faucet: Pure (RO) Water  and Clean (Filtered) Water 	Single Faucet: Pure (RO) Water
Appearance	Cabinet Type	
Product Dimensions	460 x 132 x 361mm	
Inlet Water Quality	Chlorinated City Water	
Inlet Water Pressure	15 - 55 PSI	
Operating Pressure	60 - 115 PSI	
Operating Environment	Ambient temperature 4°C-40°C, relative humidity ≤90% (indoors)	
Power Supply	110-220V, 50/60Hz	
Power	70W	
Display	<ul style="list-style-type: none"> - TDS Value; - System status indicators: Water production (Processing); Flushing; Leak; Error - Individual cartridge lifespan progress bars + Cartridge replacement reminder - Function Buttons: Select Button; Flush Button; Reset Button 	
Faucet LED Light Indicator	Yes	No
Cartridge Replacement Reminder	Alarm sound	Alarm sound
Leakage Alarm	Display + Beep	
Cartridge Type	Disposable Cartridge	
Booster Pump	Built-In	

3.4. Schematic Diagrams

Water Treatment Process Schematic Diagram

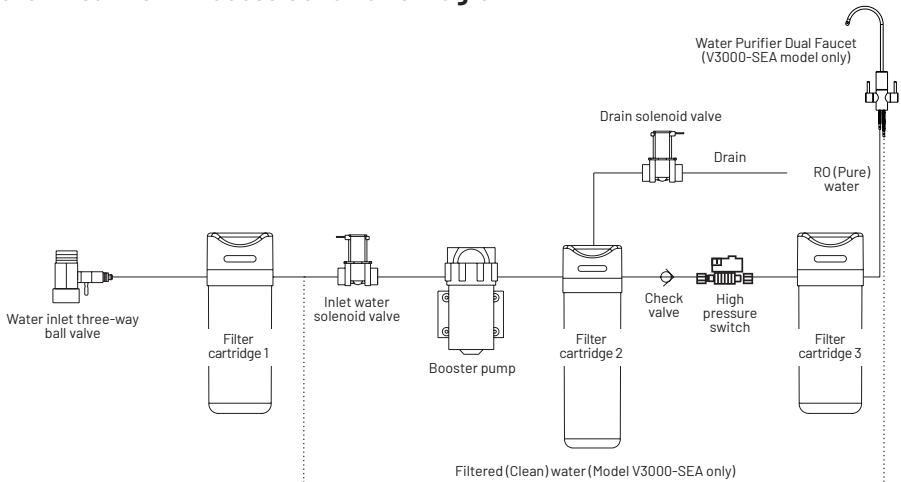

Electrical Schematic Diagram

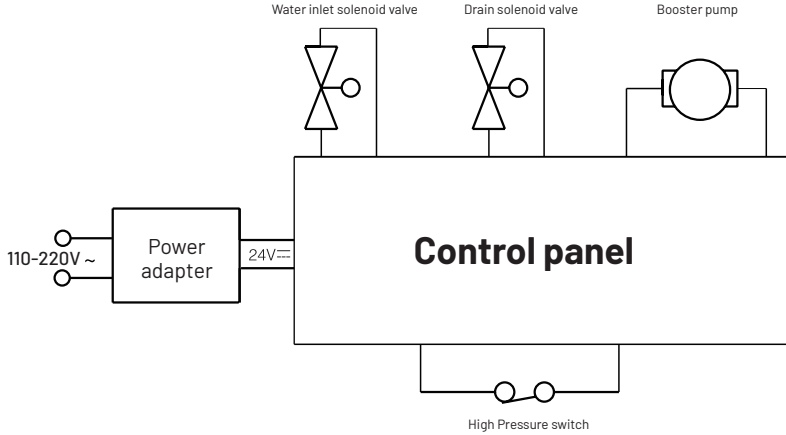

3.5. Introduction to Main Parts

S/No.	Item	Material	Specifications	Quantity	Estimated Lifespan
1	PP melt blown with activated carbon composite filter cartridge	Polypropylene + activated carbon	Φ53mm	1 piece	6-12 months
2	Reverse osmosis membrane	Aromatic polyamide	400 GPD	1 piece	24-36 months
3	Post activated carbon	Activated carbon	Φ53mm	1 piece	12 months
4	Filter housing	Polypropylene	Φ74mm	2 pieces	5 years
5	RO housing	Polypropylene	Φ107mm	1 unit	5 years
6	Dual faucet (Model V3000-SEA)	Stainless steel	-	1 piece	5 years
6.1	Single faucet (Model V15-SEA)	Copper	-	1 piece	5 years
7	PE plastic tubes	Polyethylene	-	6 m	5 years
8	Integrated waterway board	Polypropylene	-	1 piece	5 years
9	Solenoid valve	Polypropylene	DC24V	2 pieces	5 years

4. INSTALLATION AND COMMISSIONING

- Please read all instructions and precautions before installing this product.
- When selecting a mounting location of the system, take into consideration the length of tubing required for connections between existing plumbing and system components. Some installation sites may require more tubing than provided in the kit.
- Open the package and check all the items in the "PARTS INCLUDED" list are there and without any apparent damage.
- The installation instructions below serve only as a guide. The installation, commissioning and maintenance of this product must be carried out by qualified technicians designated by an authorized Pentair's distributor. Installation by unauthorized person may damage the product and damage so caused will not be covered by warranty.
- Please contact your local Pentair authorized distributor for product installation, commissioning, maintenance and after-sales services.

4.1. Tools and Materials

- Hand or electric drill (cordless preferred)
- (2) Adjustable wrenches
- Slotted and Phillips screwdrivers
- File
- Safety glasses
- Drill bits
- Tube cutter or utility knife
- Pencil
- Towel
- Bucket
- Screwdriver bits
- Scale
- Teflon tape
- Multimeter
- Tester
- Electric cable
- Insulated wiring conduit (case)
- Power socket board

If sink does not have hole for separate faucet:

- Center punch
- Hole saw or drill bit
- Safety mask

NOTE: All tools may not be necessary for installation. Read installation procedures before starting to determine what tools are necessary.

Note: Ensure personal safety when using power tools. There should not be any concealed water, electric or gas conduits at places of drilling.

4.2. Installation Precautions and Requirements

- The product is provided with a booster pump. This product can be installed on the municipal tap water supply inlet pipe.
- Accessible 110-220V power socket.
- Install the product in a clean and hygienic location, with no surrounding pollution, away from direct sunlight, flammable and explosive materials or electrical equipment, and sheltered from rain.
- The electrical circuit must be installed by certified professional personnel.
- Turn off the main power supply and modify the circuit carefully according to the user's requirement. Such work must comply with relevant electrical installation procedures and regulations.
- Upon completion of the modification, conduct a circuit check and clean up the area.

4.3. Quick Connect Instruction

The water outlets connections of the product are equipped with quick connector ports. The quick connector port allows for quick and firm connections without the use of any tools.

- Connecting and disconnecting the PE tube to the quick connector port

When connecting, pull out the horseshoe shaped clip. Cut squarely across one end of the supplied PE tube and insert the cut end fully into the connector port. Ensure that the PE tube is inserted through the seal ring of the connector. Then, tug the PE tube slightly outward to generate a small gap between the moveable plastic ring and the port opening. Reinsert the horseshoe shaped clip onto the gap to complete the connection.

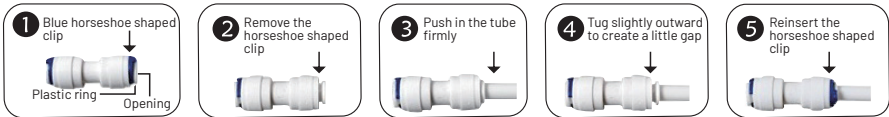

To remove the PE tube from the water outlet quick connector: First, pull out the horseshoe shaped clip. Next, push the moveable plastic ring located at the connector port inward such that it is flush with the port opening. Lastly, simply pull out the PE tube.

Do not pull out the PE tube by force.



4.4. Installation Steps

Installation of right-angle quick connectors

Press the movable plastic ring located at the connector port inward so that it is flush with the port opening. Then, pull out the 1/4" and 3/8" plug.

Remove the 1/4" and 3/8" right-angle connector from the accessory bag and insert it into the corresponding connector port as shown in the diagram on the right.

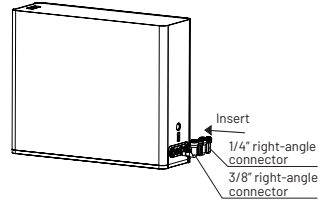

Installation of (filter) cartridges

- Remove the top cover and put aside.
- Installing the filter cartridge: Remove the filter cartridge from the product packaging, as well as the outer packaging film.
- The filter element is built into the filter cartridge canister. Insert the filter cartridge into the respective Filter Cartridge slot (check the filter cartridge numbering sequence) to insert it and twist the filter cartridge canister clockwise to lock its position.
- Insert the filter cartridges one by one, in the order shown in the diagram.
- When installing the filter cartridges, ensure that the number indicated on the filter cartridge matches the number marked on the water purification system.

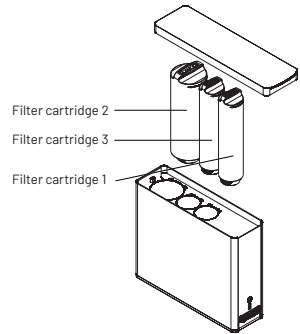

Installation Location:

Place the machine at an appropriate location in the cabinet under the sink and ensure that it is in a stable position.

Tubing Installation:

- **Installing the inlet 3-way ball valve:** Clean the installation location before shutting the main water inlet valve. Then, dismantle the pipe faucet (simple faucet or angle valve) and install the 3-way ball valve in its place (note: threaded connections should be sealed with Teflon tape or washers). Lastly, re-connect the original faucet or angle valve.
- **Connecting to the water inlet:** Connect one end of the PE tube to the ball valve connected to the municipal tap water pipe. Then connect the other end of the PE tube to the water inlet connecting port (marked as "Inlet") on the main machine.
- **Installing the water purification system's faucet:** At the position where the faucet is to be installed, make a mark on the stainless steel sink with a hammer and center punch (to facilitate drilling). Drill a Φ 29mm (model: V3000-SEA) or Φ 12 mm (model: V15-SEA) hole with an electric drill and install the faucet.
- **Connection for clean (filtered) water (for model V3000-SEA only):** Connect one end of the 1/4" straight quick-connector onto the faucet connector marked "Clean Water". Cut an appropriate length of 1/4" PE tube and insert one end into the 1/4" straight quick-connector; then the other end into the clean water connector port on the water purification system.

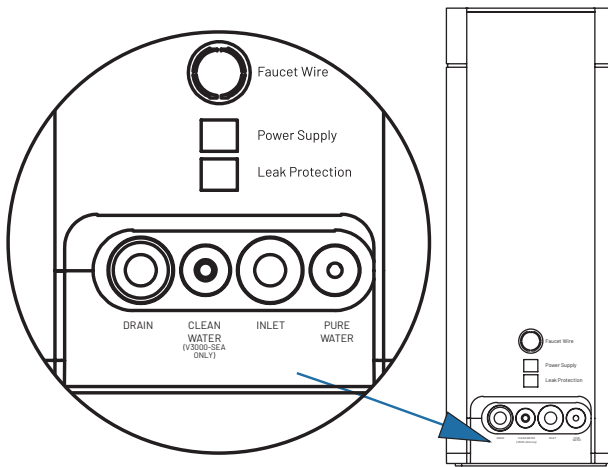

- **Connection for pure (RO) water:** Connect one end of the 1/4" straight quick-connector onto the faucet connector marked "Pure Water". Cut an appropriate length of 1/4" PE tube. Then insert one end into the 1/4" straight quick-connector and the other end into the pure water connector port on the water purification system.
- **Connection for drain water:** Prepare an appropriate length of 3/8" PE tubing and connect it to the drain water connector port on the water purification system. Connect the other end to the drainage pipe, ensuring proper fitting to prevent it from falling out (**note: the drain water should not be discharged into a tank without spill-over protection as overflowing may cause water spill**).
- **Flushing RO membrane and filter cartridges:** See Section 5.1 System Start-up

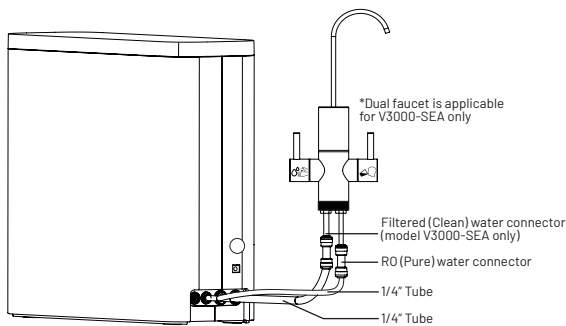

Note:

- If the power supply is cut off after water production, the machine will stop producing water. If there is no water flow from the faucet, check to see if the power supply is connected.
- Before using the product, please follow the steps set out in Section 5.1. to flush the filter cartridges.

5. OPERATING INSTRUCTIONS

NOTE: The reverse osmosis membrane is treated with a sanitizing agent to prevent microbial contamination, which should be flushed from the system. While using the system for the first time or replacing the reverse osmosis membrane (second-stage filter), it is recommended to perform rinsing for 60 minutes and soaking the RO membrane for 24 hours before using it normally.

NOTE: The granular activated carbon filter element (third-stage filter) may contain fine black carbon particles. These fines are harmless, but may make the water appear grey in color. The carbon fines are flushed from the system during the initial flushing of the system.

CAUTION Visually check the entire system for leaks. If a leak is present, see section 7, Troubleshooting.

5.1. Initial Start-up Instructions

- When using for the first time, turn on the faucet and open the inlet valve to let water enter the water purification system. When water begins to flow out of the faucet, shut the faucet immediately and maintain the pressure for 30 minutes before checking for any leaks in the pipe network. If no leakage is detected, follow the steps set out in Section 5.1.1. and 5.1.2. to flush the machine and filter cartridges.

5.1.1. Flushing RO Membrane

- (A) Turn on the cold water supply and ensure the inlet water supply adapter valve is open.
- (B) Lift the faucet handle to lock it in the open position and let it flush for 30 min to 1 hour.
- (C) Close the faucet. Allow the RO membrane to soak for 12 to 24 hours.
- (D) Ensure power supply is switched on.
- (E) Continue to periodically check the installation for leaks. Open the faucet to flush for about 5 minutes.

5.1.2. Flushing Activated Carbon Filter Cartridge

- (A) Ensure inlet water supply valve is open.
- (B) Lift the faucet handle to open position and let it flush for approximately 30 minutes (until clear water is being dispensed from the faucet).

NOTE: Initially, the water may appear cloudy. This is a result of air trapped in the post-polishing filter. It is not harmful and will disappear in a matter of minutes. It may take up to a week after installing a new post-polishing filter for the trapped air to dissipate.

The system is ready for operation. You can now enjoy quality water from your Reverse Osmosis System.

5.2. Normal Operation

- During normal use, simply turn on the faucet.
- After a prolonged period of non-use, flush the system until clear water is being dispensed out of the faucet.

LED Screen

Every time the power is turned on, the LED on the display will blink once. Thereafter, the machine goes into operation state. Every key pressed is acknowledged by an audible beep. If there is no operation for 5 minutes, the display will go into screen-saver mode. Pressing any key will wake up the display. The machine then immediately enters the operation state.

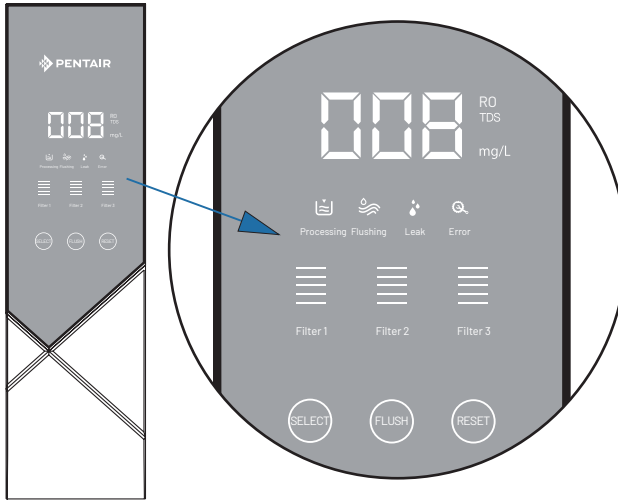

*Front display panel color depends on model.

Water Production

Open the faucet, the machine will start producing water. During water production, the Processing Icon and the text "Processing" will light up. During standby, the Processing Icon and the text "Processing" will turn off.

Flushing

- Each time the machine is powered on, it will automatically flush for 30 seconds.
- For every 10 minutes of accumulated water production, it will flush for 10 seconds.
- Continuous water production of 10 minutes, it will flush for 15 seconds.
- Press the 'Flush' button to flush the machine for 30 seconds before entering the operation state.
- In the flushing state, press the 'Flush' button to abort the flushing process.
- While flushing, the Flushing Icon and the text "Flushing" will light up.
- If flushing is aborted, the Flushing Icon and the text 'Flushing' will turn off.

5.3. Water Purification System Monitoring

Error Mode: After 1 hour of continuous water production or flushing, the machine will enter error mode by default and implement the following protective measures:

- All functions will become inoperative.
- Display alarm is activated: Error Icon and Text displayed.
- Audio alarm is activated: 6 beeps.
- After troubleshooting and resolving the fault, the machine will return to normal operation after the power is turned on again.
- Error Icon and Text will not light up under normal operating conditions.
- Press the "Reset" button or turn the power off and on again to resume normal operation.

Leakage Detection

If continuous monitoring of the leakage sensor reveals 10 consecutive leakage signals, the product will stop operating.

The Leak Icon and Text will light up, and the audio alarm will sound 6 beeps.

When the leakage fault is eliminated, the leakage alarm will cease and the machine automatically returns to normal operation.

Dual Faucet (Model V3000-SEA only):

- When the power is turned on, the Blue LED flashes once followed by the red LED.
- Filter cartridge change reminder: When the lifespan of any of the filter cartridge falls below 5%, the blue LED on the faucet blinks whenever the machine is in water production mode, and stops blinking when the machine is on standby.
- Filter cartridge lifespan is up: When the lifespan of any of the filter cartridge is up, the red LED on the faucet lights up whenever the machine is in water production mode.

6. MAINTENANCE AND CARE

6.1. Filter Cartridge Replacement Cycle

Replace the filter cartridge according to the reminder for the corresponding filter cartridge on the water purification system.

The replacement cycle for a filter cartridge depends on the water supply quality and volume of filtered (Clean)(for model V3000-SEA only) and RO (Pure) water usage by the user. Regular cartridge replacement ensures the normal operation of the water purification system and the quality of clean (model V3000-SEA only) and pure water produced.

Note:

1. In areas where an elevated water tank is installed, the supplied water may contain more sediments as the water tank might not be cleaned regularly. In such situations, extra attention must be given to the replacement of Filter Cartridge 1.
2. Increase in total dissolved solids (TDS): This indicates degradation in the quality of water produced and time to replace filter cartridges.

6.2. Steps for Replacement of Filter Cartridge

Replace the filter cartridge according to the machine's lifespan reminder or the recommended replacement cycle. Please contact your local Pentair authorized distributor for replacement of filter cartridges.

1. Turn off power to the water purification system and shut the inlet 3-way ball valve. Open the faucet and discharge it until no more water flows out of the faucet.
2. Remove the top cover and put aside. The filter cartridge is built into the filter canister. Twist the filter cartridge anti-clockwise to remove it and clockwise to install the filter cartridge, as shown in the diagram below.

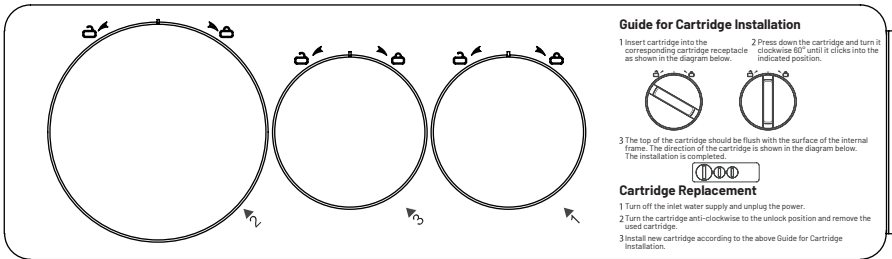

Twist anti-clockwise to remove, clockwise to install

3. Upon installation of the filter cartridges, open the inlet 3-way ball valve, turn the machine on and perform a Reset operation (For details, see Section 6.3.).

Note:

The lifespan of the filter cartridge depends on the geographical location, inlet water quality, season, and usage volume. The actual replacement cycle may differ.

6.3. Filter Cartridge Lifespan Reset

On the display, press and hold "Reset" button for 3 seconds. The buzzer will sound a long beep before entering the Filter Cartridge Reset Selection State. Press the "Select" button again. The buzzer will sound a short beep and the display will cycle through each of the three filter cartridges for selection, with the selected filter cartridge blinking (the others will be turned off). Press and hold the "Reset" button for 3 seconds again. The buzzer will sound a long beep and the selected filter cartridge's lifespan will be reset before the machine exits the Reset Function. Repeat the above steps to select another filter cartridge that needs to be reset.

If there is no operation within 10 seconds after entering the Reset Function, the machine will automatically abort the Filter Cartridge Lifespan Reset Function.

6.4. Water Purification System Exterior Cleaning

- When cleaning the product, do not use strong volatile solvents such as soap, detergent, thinner, gasoline or alcohol. Using such cleaning agents may cause cracks, scratches or discolouration.
- Do not clean the machine by spraying water directly onto it.

7. TROUBLESHOOTING

Problem	Possible Cause(s)	Solution
The system does not produce water or Reduced outlet water flowrate	PE tube is bent	Remove bend from PE tube
	Check if the three-way ball valve is closed	Open the three-way ball valve
	Check if the inlet water supply is disrupted	Wait for the inlet water supply to resume
	Check if filter cartridge 1 is clogged	Replace filter cartridge 1
	Check if the water pressure is lower than the rated pressure	Install a pressure booster
	Check if the water temperature is too low	NA
The equipment does not operate	Faulty power supply	Check if there is power
	Faulty power adapter	Replace the power adapter
	The equipment does not have water supply	Check if there is water flowing from the source. Once there is water, turn the power off and on to restart.
Abnormal taste	Check if the machine has not been used for a long period of time	Flush the filter cartridges (except the RO membrane) for 5 minutes. If the taste does not improve, replace the filter cartridges.
	Poor inlet water quality	Check inlet water quality.
	Check if the filter cartridge has not been replaced for a long time	Replace the filter cartridge
Abnormal sounds emitted during operation	Check if the power supply voltage is normal	Inform maintenance personnel to perform adjustment or replacement
	Check if the inlet water flow is sufficient	Increase the water flowrate of the source water supply
	Check if any water has leaked into the transformer	Inform maintenance personnel to perform adjustment or replacement
	Faulty pump	Inform maintenance personnel to perform adjustment or replacement

8. TERMS AND CONDITIONS OF WARRANTY

- (1) The warranty period is 1 year from the date of purchase. During the warranty period, Pentair (Company) is responsible for providing free warranty for faults arising from normal operation and use according to the installation manual and user's manual. Pentair will charge repair and maintenance fees after the warranty expires.
- (2) The user should keep valid purchase invoice, which serves as the basis for after-sales service.
- (3) Installation, maintenance and repair services will be provided by Pentair's authorized distributors. In the event that the user is unable to present the warranty card or valid purchase invoice, Pentair will deem the warranty to have expired and charge the relevant fees.
- (4) Warranty will be void in the following conditions:
 - Installation by personnel who are not authorized by Pentair;
 - Product malfunction or damage resulting from user's failure to follow the instructions described in user's manual to operate the system;
 - Error or damage caused by the user's self-repair or modification of the equipment;
 - Error or damage caused by force majeure (including but not limited to natural disasters such as fires, floods, earthquakes, lightning strikes, etc.);
 - Error or damage caused by human factors (including but not limited to drop, knock, etc.);
 - Where the user is unable to present warranty card or purchase invoice, or the content of the invoice has been altered;
 - Any problems caused by using parts that are not approved by Pentair.
- (5) The repair parts replaced during the warranty period are owned by Pentair.
- (6) Warranty does not cover for all consumables, such as filter element and materials.
- (7) Pentair reserves the right to charge a certain service fee for maintenance or repair service provided on-site in remote areas.

9. MAINTENANCE RECORDS

Date	Cause of Error	Replacement Part	Maintenance Personnel
Remarks			

Distribution and Service by:

(Distributor Stamp Here)

Date of Purchase:



371 He Shan Road | New District Suzhou | Jiangsu 215011 | China | pentair.com¹

All Pentair trademarks and logos are owned by Pentair. All other brands or product names are trademarks or registered marks of their respective owners. Because we are continuously improving our products and services, Pentair reserves the right to change specifications without prior notice.
00-00000 00/00 ©2020 Pentair. All Rights Reserved.