

# HIGH FLOW CSR TWIN 7FC

System Part Number: EV9329-72



## System Description

The **High Flow CSR Twin 7FC** filtration system combines multiple treatment technologies in one system to serve the unique needs of different equipment from two separate manifold outlets. Primary filtration includes a system prefilter and exclusive Fibredyne™ II bacteriostatic media to filter sediment down to 0.2 micron\* and provides chlorine taste & odor reduction at a flow rate of 5 gpm for 50,000 gallons. The first system outlet supplies filtered water to fountain and cold beverage applications. Before the second system outlet, the filtered water passes through an integrated scale inhibitor cartridge to help minimize the potential for hard scale formation<sup>†</sup> on the surfaces and components of ice machines and coffee brewer equipment. This system is certified under NSF/ANSI Standards 42 and 53.

## Applications

- ◆ Multiple applications
  - One system feeds both fountain, ice, and coffee equipment

## Features • Benefits

- ◆ One system with two outlets delivers optimal water treatment for fountain, ice, and coffee
- ◆ Integrated scale inhibitor cartridge helps minimize the potential for scale formation<sup>†</sup> and help ensure reliable, efficient equipment operation
- ◆ Initial Prefilter traps larger particles of dirt and sediment to support overall system performance resulting in reduced maintenance and downtime
- ◆ Proprietary Fibredyne II media reduces chlorine taste & odor while providing particulate reduction down to 0.2 micron\*
- ◆ Fibredyne II media inhibits the growth of bacteria within the filter to guard against media fouling and optimize performance
- ◆ Inlet shutoff valve, flushvalve, and pressure gauges simplify service and monitor operating performance
- ◆ Quick-change (QC) cartridges make changing cartridges simple and sanitary
- ◆ Reduces a range of contaminants to help ensure clearer, fresher water for consistently crystal clear ice, and great-tasting hot and cold beverages
- ◆ NSF/ANSI Standard 42 certified for Bacteriostatic Effects and the Reduction of Chlorine Taste & Odor, and Particulate Class I
- ◆ NSF/ANSI Standard 53 certified to reduce cysts such as *Cryptosporidium* and *Giardia* by mechanical means

## Installation Tips

- ◆ Choose a mounting location suitable to support the weight of the system while operating.
- ◆ Install vertically and allow 21/2" (6.35 cm) clearance below the cartridge for easy removal and replacement.
- ◆ Feed water temperature must not exceed 100°F (38°C).
- ◆ Do not install where the system could be exposed to freezing temperatures.
- ◆ Feed water supply pressure must not exceed 125 psi (non-shock). When pressure exceeds 85 psi, a pressure reducing valve is recommended.
- ◆ Flush cartridges by running water through the system for five (5) minutes.
- ◆ For more details, see the installation, operation, and maintenance guide included with the system.

\*Validated by ISO 17025 accredited lab for 99.999% reduction of *Pseudomonas diminuta* following the ASTM F838-05 protocol for the validation of 0.2 µm sterilizing grade filters.

<sup>†</sup>As tested by Pentair.

EPA Est. 002623-IL-002

# HIGH FLOW CSR TWIN 7FC

EV9329-72

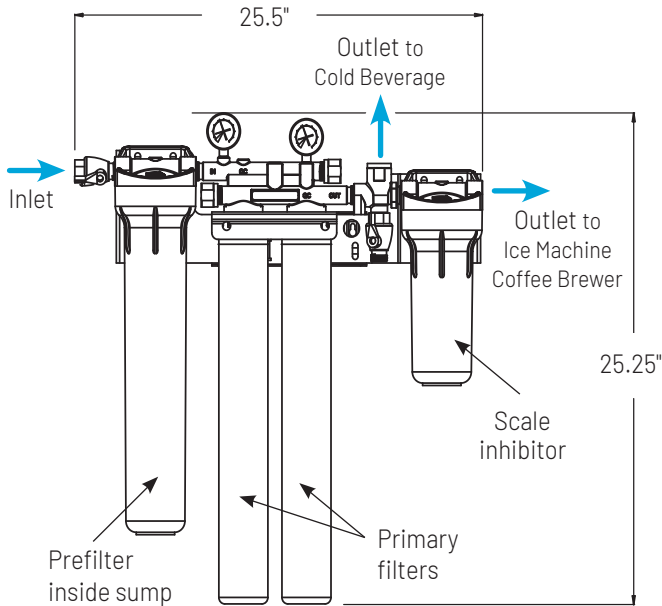

## Specifications

System	Performance
Overall Dimensions 25.25" H x 25.5" W x 6.75" D (64.1 cm x 65 cm x 17.2 cm)	Service Flow Rate 5.0 gpm (18.93 lpm)
Connections Inlet Connection: 3/4" FNPT Outlet Connection: 3/4" FNPT	Rated Capacity 50,000 gallons (189,271 L)
Operating Pressure 10 - 125 psi (0.7 - 8.6 bar)	Chlorine Taste & Odor Reduction Yes
Water Temperature 35 - 100°F (2 - 38°C)	Particulate Reduction Yes
Operating Weight 42 lbs (19 kgs)	Bacteriostatic Effects Yes
Shipping Weight 30 lbs (13.6 kgs)	Cyst Reduction Yes
Electrical Connection None required	Turbidity Reduction Yes

For Pentair Everpure Product Warranties visit:  
<http://pentair.com/assets/foodservice-warranty>

It is recommended that filter cartridges be replaced every six (6) months on a regular scheduled program, or when capacity is reached or if water pressure or flow to equipment becomes inadequate.

Always replace filter cartridges at least once per year.

The contaminants or other substances removed or reduced by this drinking water system are not necessarily in your water. Do not use with water that is microbiologically unsafe or of unknown quality without adequate disinfection before or after the system.

Systems certified for cyst reduction may be used on disinfected water that may contain filterable cysts.

Since the conditions under which our products may be used are beyond our control, we cannot accept any liability with respect to the improper installation, application and/or use of our products.

## REPLACEMENT CARTRIDGES

Model	Qty	Description	Part No
EC210	1	Prefilter	EV953426
7FC	2	Primary filter	EV969261
SS-IMF	1	Scale inhibitor	EV979932

System Tested and Certified by NSF International against NSF/ ANSI Standards 42 and 53 for the reduction of:



STANDARD NO. 42 – AESTHETIC EFFECTS Bacteriostatic Effects Chemical Reduction Taste & Odor Chlorine Mechanical Filtration Nominal Particulate Class I	STANDARD NO. 53 – HEALTH EFFECTS Mechanical Filtration Cyst Turbidity
--	---



## Pentair Offices in South East Asia

### Singapore

390 Havelock Road  
#04-01 King's Centre  
Singapore 169662  
Tel: +6567685900

### Thailand

16th Floor, The Ninth Towers  
Grand RAMA 9, Tower B  
33/4 Rama 9 Road, Huaykwang  
Bangkok 10310, Thailand  
Tel: +6621681092

### Philippines

5th Floor MAIA Suites  
1747 Nicanor Garcia Street corner  
D.Oliman Street Makati City, Philippines  
Tel: +632824 3825

All Pentair trademarks and logos are owned by Pentair. All other brands or product names are trademarks or registered marks of their respective owners. Because we are continuously improving our products and services. Pentair reserves the right to change specifications without prior notice. Pentair is an equal opportunity employer.

©2022 Pentair. All Rights Reserved.